

Double-Data-Rate OPI/HPI Xccela PSRAM

Specifications

- Single Supply Voltage:
 - $V_{DD} = 1.62$ to $1.98V$
 - $V_{DDQ} = 1.62$ to $1.98V$
- Interface: Octal Peripheral interface (OPI) and Hexadecimal Peripheral interface (HPI) with Xccela mode,
 - Two bytes transfer per clock – X8
 - Two words transfer per clock – X16
 - Mode register configurable X8(default)/X16
 - Note: 1 Word = 2 Bytes in this document.
- Performance: Clock rate up to 250MHz, 500MBps read/write throughput – X8 1GBps read/write throughput – X16
- Organization: 128Mb in X8 mode (default)
 - 16M x 8bits with 2048 bytes per page
 - Column address: AY0 to AY10
 - Row address: AX0 to AX12
- Organization: 128Mb in X16 mode
 - 8M x 16bits with 1024 Words per page
 - Column address: AY0 to AY9
 - Row address: AX0 to AX12
- Refresh: Self-managed
- Operating temperature range
 - $T_{OPER} = -40^{\circ}C$ to $+85^{\circ}C$ (standard range)*
 - $T_{OPER} = -40^{\circ}C$ to $+105^{\circ}C$ (extended range)*
- Typical Standby Current:
 - $19.5\mu A$ @ $25^{\circ}C$ (Halfsleep™ Mode with data retained)
- Maximum Standby Current:
 - $590\mu A$ @ $105^{\circ}C$
 - $420\mu A$ @ $85^{\circ}C$

Features

- Low Power Features:
 - Partial Array Self-Refresh (PASR)
 - Auto Temperature Compensated Self-Refresh (ATCSR) self-managed by a built-in temperature sensor
 - Ultra Low Power Halfsleep™ mode with data retention.
- Software reset
- Reset pin available
- Output driver LVCMOS with programmable drive strength
- Data mask (DM) for write operation
- Data strobe (DQS) for high speed read operation
- Register configurable write and read latencies
- Write burst length
 - max 2048 Bytes in X8/1024 Words in X16
 - min 2 Bytes in X8 /2 Words in X16
- Wrap & hybrid burst in
 - 16/32/64/2K Bytes length in X8 mode.
 - 16/32/64/1K Words length in X16 mode.
- Linear Burst Commands
- Row Boundary Crossing (RBX) read operations enabled via Mode Register (maximum frequency of 200MHz)
- X16 mode can be configured by setting MR8[6]=1 (default is X8 mode and MR8[6]=0)
- Optional host control of refresh rate via. MR0[7]

Table of Contents

1	<i>Table of Contents</i>	
1	Table of Contents.....	2
2	Package Information.....	4
2.1	Package Types : BGA 24B X8/X16 (BG).....	4
2.2	Package Outline Drawing.....	5
3	Ordering Information:.....	6
4	Signal Table	7
5	Block diagram.....	8
6	Power-Up Initialization	9
6.1	Power-Up Initialization Method 1 (via. RESET# pin).....	9
6.2	Power-Up Initialization Method 2 (via. Global Reset)	10
7	Interface Description	11
7.1	Address Space	11
7.2	Burst Type & Length.....	11
7.3	Command/Address Latching.....	11
7.4	Command Truth Table	11
7.5	Read Operation	12
7.6	Write Operation	16
7.7	Control Registers.....	17
7.8	Halfsleep™ Mode	25
7.9	Deep Power Down Mode.....	26
8	Electrical Specifications:	27
8.1	Absolute Maximum Ratings.....	27
8.2	Input Signal Overshoot	28
8.3	Pin Capacitance.....	28
8.4	Decoupling Capacitor Requirement.....	29
	Low ESR cap C1:	29
	Large cap C2:.....	29
8.5	Operating Conditions	29
8.6	DC Characteristics	30

8.7	ISB Partial Array Refresh Current.....	31
8.8	AC Characteristics	32
9	Change Log.....	35

2 Package Information

2.1 Package Types : BGA 24B X8/X16 (BG)

The APS128XXO-OBx is available in mini-BGA 24B package 6 x 8 x 1.2mm, ball pitch 1.0mm, ball size 0.4mm, package code “BG”.

- Ball Assignment for MINI-BGA 24B

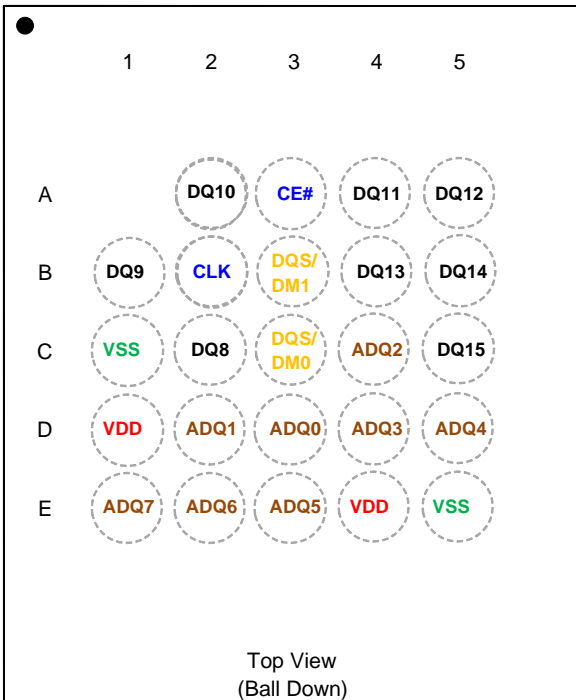

(6x8x1.2mm)(P1.0)(B0.4)

Note: Ball out of X8/X16 mode in Part Number
APS128XXO-OBx-BG for 128Mb

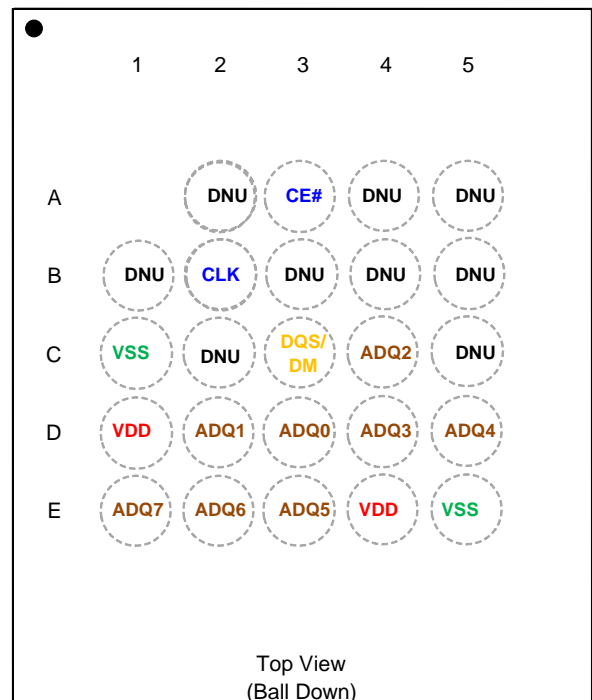

(6x8x1.2mm)(P1.0)(B0.4)

Note: Ball out of X8 mode only if use in Part Number
APS128XXO-OBx-BG for 128Mb
DNU: Do Not Use for X8 mode only

2.2 Package Outline Drawing

BGA 24B , package code BG

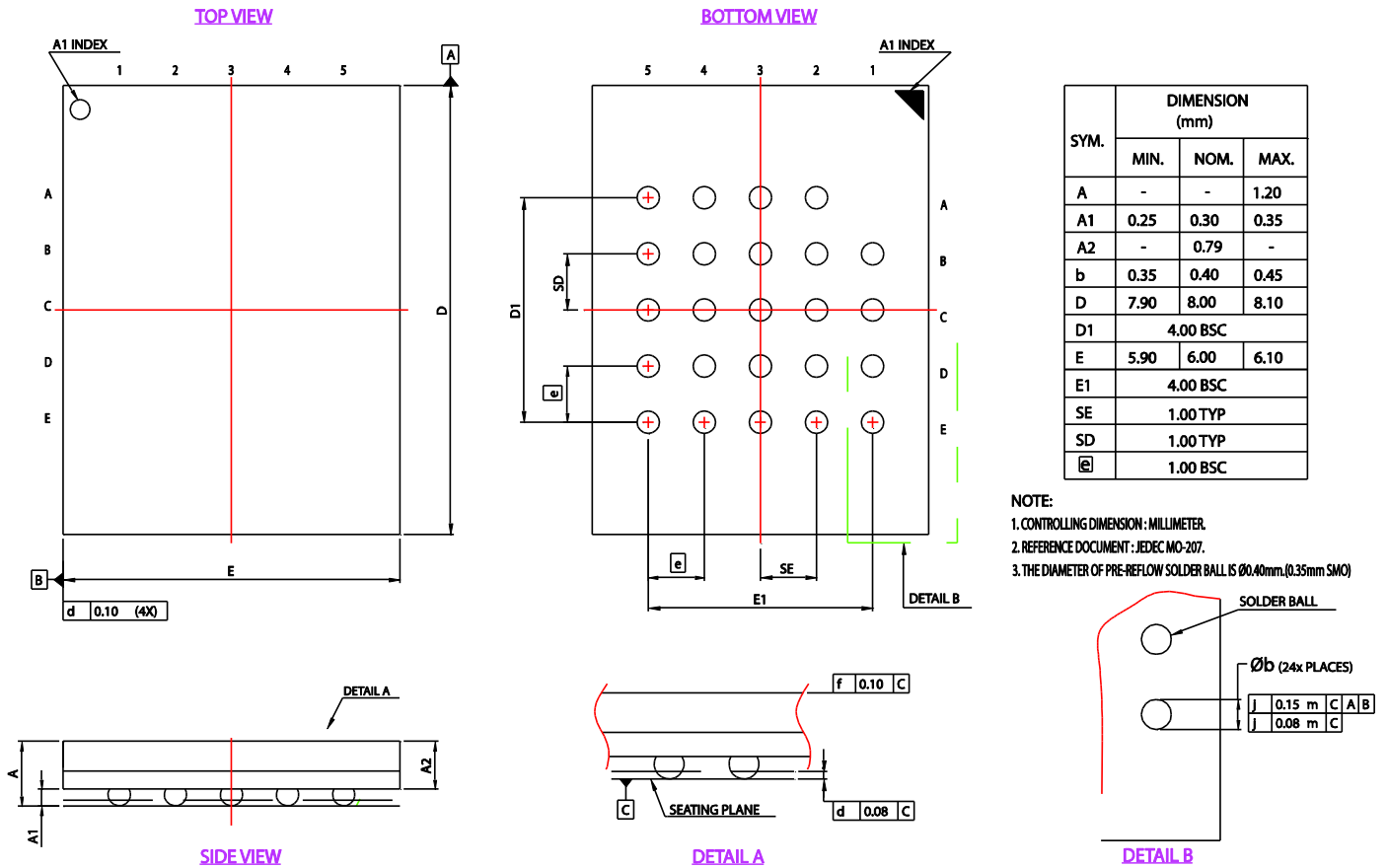

3 Ordering Information:

Table 1: Ordering Information

Part Number	IO	Temperature Range	Max Frequency	Note
APS128XXO-OB9	X8/X16	T _j =-40°C to +85°C	250 MHz	Bare die, SIP
APS128XXO-OBX9	X8/X16	T _j =-40°C to +105°C	250 MHz	Bare die, SIP
APS128XXO-OBX9-BG	X8/X16	T _c =-40°C to +105°C	200 MHz	BGA 24B (only for validation purpose)

IOT_SOPI_PN rule

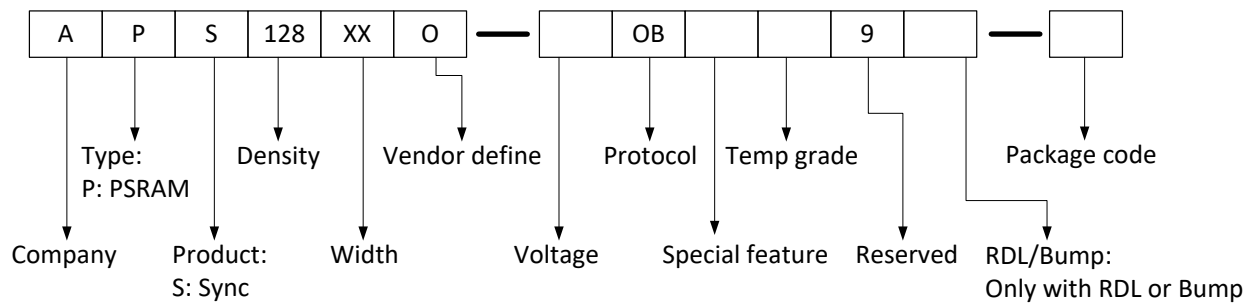

4 Signal Table

All signals are listed in Table 2.

Table 2: Signals Table

<i>Symbol</i>	<i>Type</i>	<i>Description</i>	<i>Comments</i>
V _{DD}	Power	Core & IO supply 1.8V	V _{DDQ} short to V _{DD} internally.
V _{SS}	Ground	Core& IO supply ground	
A/DQ[7:0]	IO	Address/Data bus [7:0]	Used in X8 and X16
DQ[15:8]	IO	Data bus [15:8]	Used in X16 only
DQS/DM<0>	IO	DQ strobe clock for DQ[7:0] during all reads, Data mask for DQ[7:0] during memory writes. DM is active high. DM=1 means “do not write”.	Used in X8 and X16
DQS/DM<1>	IO	DQ strobe clock for DQ[15:8] during memory reads, Data mask for DQ[15:8] during memory writes. DM is active high. DM=1 means “do not write”.	Used in X16 only
CE#	Input	Chip select, active low. When CE#=1, chip is in standby state.	
CLK	Input	Input clock	
RESET#	Input	Reset signal, active low. Optional, as the pad is internally tied to a weak pull-up and can be left floating.	May not be available for all package types

5 Block diagram

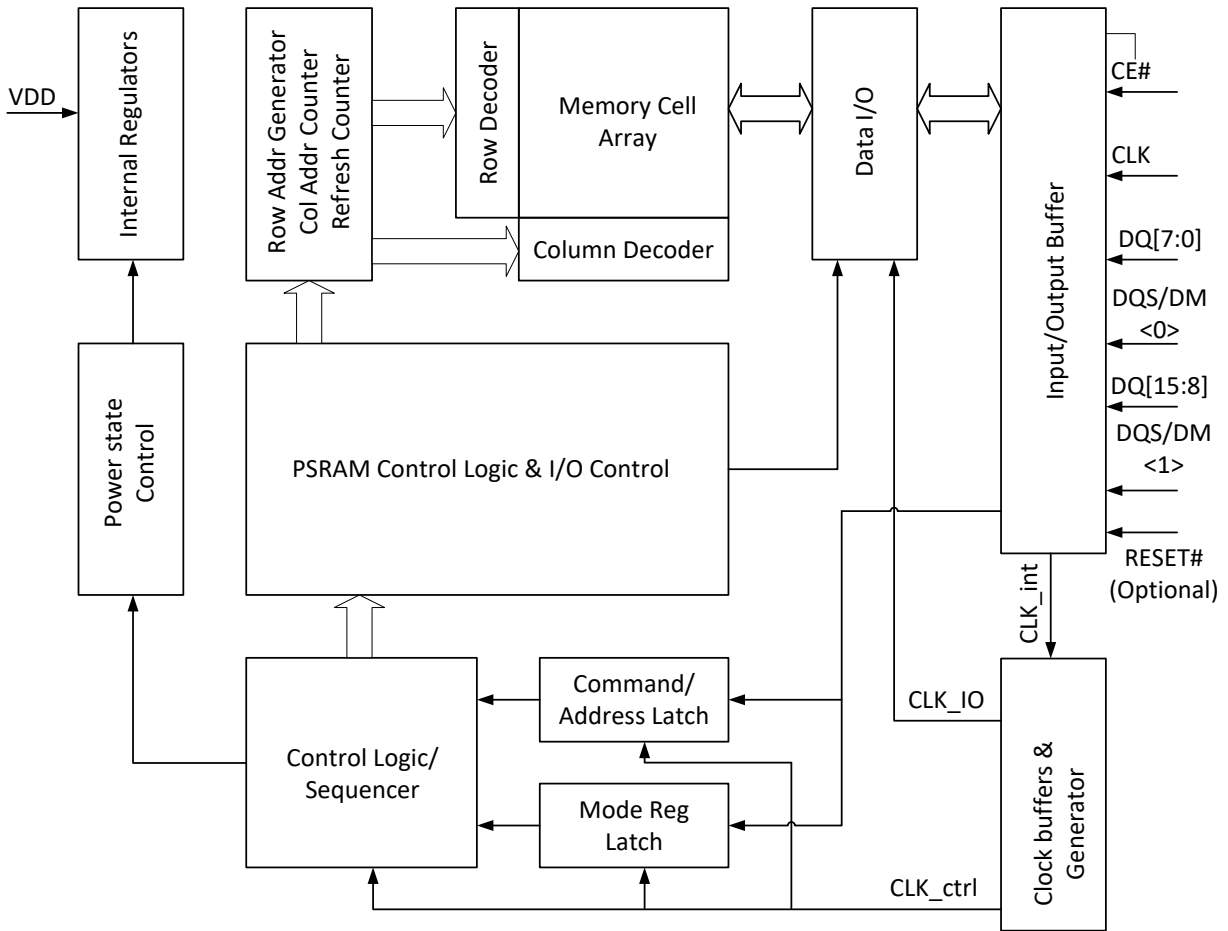

6 Power-Up Initialization

Octal DDR products include an on-chip voltage sensor used to start the self-initialization process. V_{DD} and V_{DDQ} must be applied simultaneously. When they reach a stable level at or above minimum V_{DD} , the device is in Phase 1 and it requires $150\mu\text{s}$ to complete its self-initialization process. System host can then proceed to Phase 2 of the initialization described in section 6.1.

During Phase 1 CE# should remain HIGH (track V_{DD} within 200mV); CLK should remain LOW.

After Phase 2 is complete the device is ready for operation, however Halfsleep™ entry and Deep Power Down (DPD) entry are not available until Halfsleep™ Power Up (t_{HSPU}) or DPD Power Up (t_{DPDp}) durations are observed.

6.1 Power-Up Initialization Method 1 (via. RESET# pin)

The RESET# pin can be used to initialize the device during Phase 2 as follows:

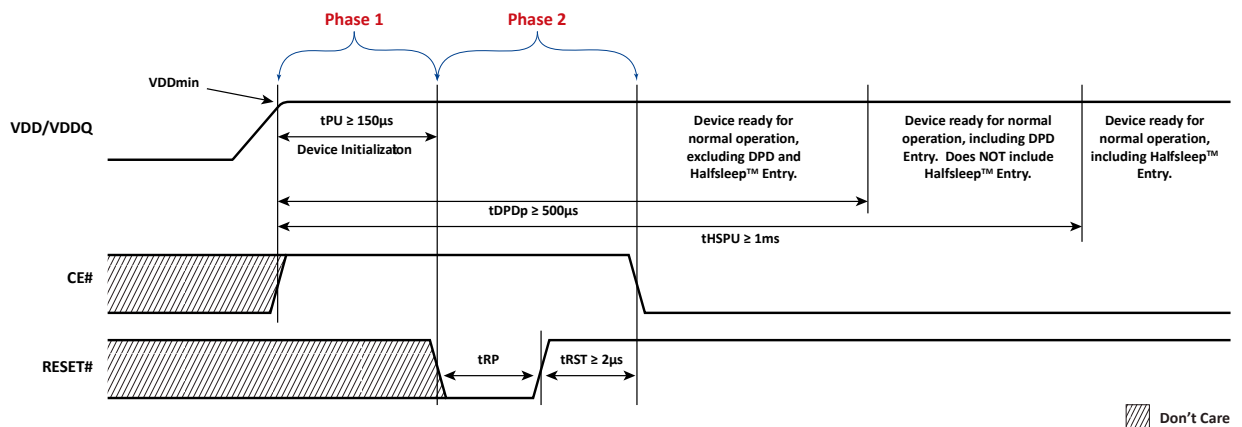

Figure 1: Power-Up Initialization Method 1 RESET#

The RESET# pin can also be used when CE#=high at any time after the device is initialized to reset all register contents. Memory content is not guaranteed. Timing requirements for RESET# usage are shown below.

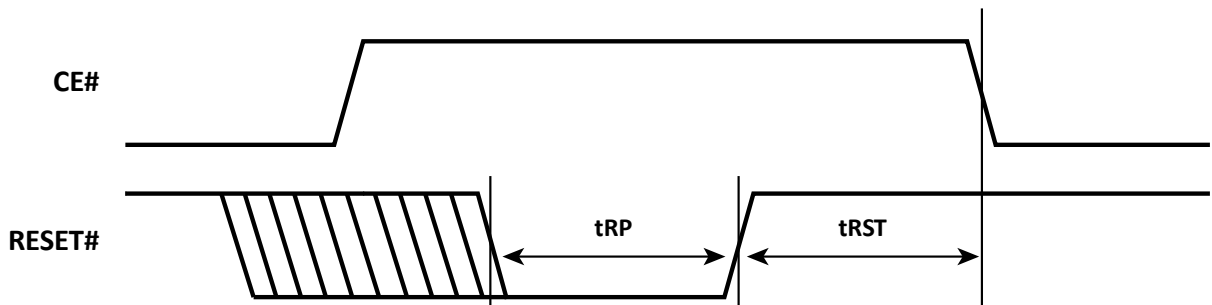

Figure 2: RESET# Timing

6.2 Power-Up Initialization Method 2 (via. Global Reset)

As an alternate power-up initialization method, after the Phase 1 150 μ s period the Global Reset command can also be used to reset the device in Phase 2 as follows:

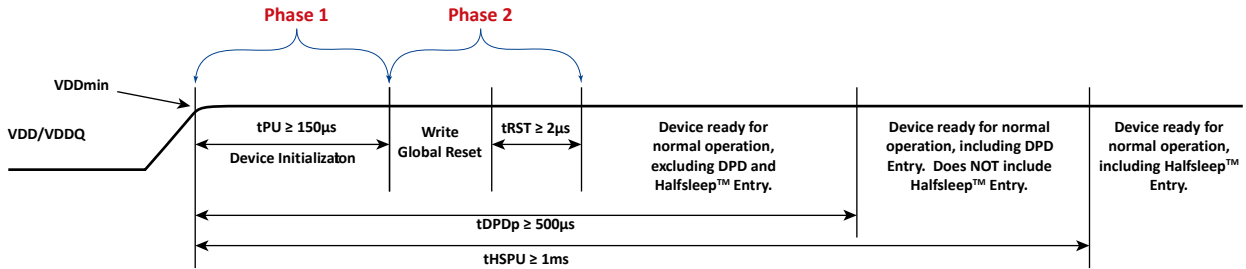

Figure 3. Power-Up Initialization Method 2 Timing with Global Reset

The Global Reset command resets all register contents. Memory content is not guaranteed. The command frame is made of 4 clocked CE# lows. Cloning is optional during tRST. The Global Reset command sequence is shown below.

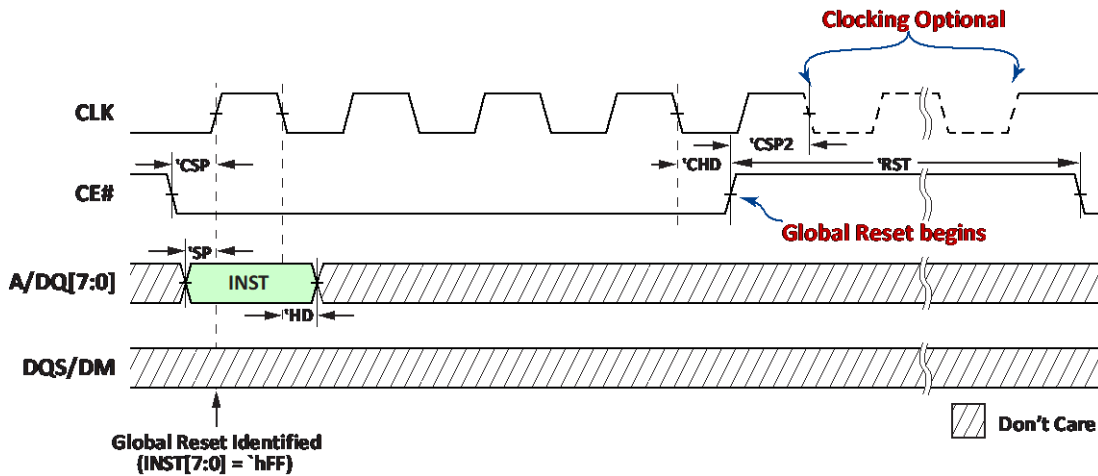

Figure 4: Global Reset

7 Interface Description

7.1 Address Space

Octal DDR PSRAM device is byte-addressable(X8)/word-addressable(X16). Memory accesses must start on even addresses (A[0]=0). Mode Register accesses can start on even or odd address.

7.2 Burst Type & Length

Read and write operations are default Hybrid Wrap 32 mode. Other burst lengths of 16, 32, 64 or 2K bytes in standard or Hybrid wrap modes are register configurable (16, 32, 64 and 1K words configurable in X16 mode). The device also includes command burst options for Linear Bursting (see Table 20). Bursts can start on any even address. Write burst length requires a minimum of 2 bytes(X8)/2 words (X16). Read has no minimum length. Both write and read have no restriction on maximum burst length as long as tCEM is met.

7.3 Command/Address Latching

After CE# goes LOW, instruction code is latched on 1st CLK rising edge. Access address is latched on the 3rd, 4th, 5th & 6th CLK edges (2nd CLK rising edge, 2nd CLK falling edge, 3rd CLK rising edge, 3rd CLK falling edge).







7.4 Command Truth Table

The Octal DDR PSRAM recognizes commands listed in the following table. Instruction and address are input through A/DQ[7:0] pins. Host must send correct instruction and address format according to the following table.

Note that CA[10] is only used in X8 mode and it is ignored in X16 mode.

Note that Linear Burst commands, 20h and A0h, ignore burst setting defined by MR8[2:0].

Note that only Linear Burst Read command is capable of performing row boundary crossing (RBX) read function.

Command	1st CLK		2nd CLK		3rd CLK	
						
Sync Read	00h		A3	A2	A1	A0
Sync Write	80h		A3	A2	A1	A0
Linear Burst Read	20h		A3	A2	A1	A0
Linear Burst Write	A0h		A3	A2	A1	A0
Mode Register Read	40h		x			MA
Mode Register Write	C0h		x			MA
Global Reset	FFh		x			

Remarks: x = don't care (V_{IH}/V_{IL})

A3 = 8'bx {unused address bits are reserved}

A2 = RA[12:5]

A1 = RA[4:0], CA[10:8] { CA[10] is used only in X8 mode}

A0 = CA[7:0]

MA = Mode Register Address

7.5 Read Operation

After address latching, the device initializes DQS/DM to '0 from CLK rising edge of the 3rd clock cycle (A1). See Figure 5 below.

Output data is available after LC latency cycles, as shown in Figure 6 & Figure 7 LC is latency configuration code defined in Table 5 and Table 6. When data is valid, A/DQ[7:0] and DQS/DM follow the timing specified in Figure 8. Synchronous timing parameters are shown in Table 30 & Table 31. CE# should be kept low until the last byte of data has been received by the host.

In case of internal refresh insertion, variable latency output data may be delayed by **up to** (LCx2) latency cycles as shown in Figure 7. True variable refresh pushout latency can be anywhere **between** LC to LCx2. The 1st DQS/DM rising edge after read pre-amble indicates the beginning of valid data.

In X16 mode DQ [15:8] will not receive INST/ADD, instead they will remain Hi-Z until read latency and then start pumping out data, similar to DQ [7:0].

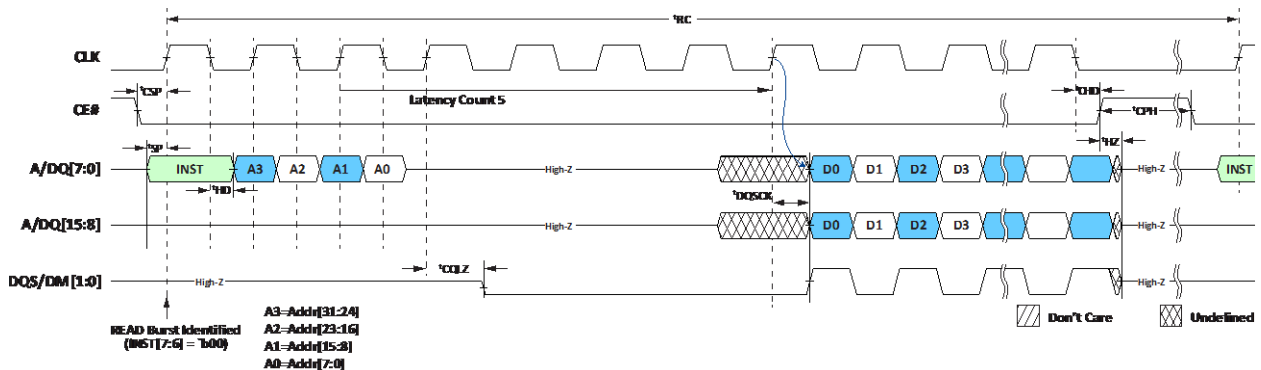

Figure 5: Synchronous Read

If RBX is enabled (MR8[3] written to 1) and a Linear Burst Read Command ('h20) is issued, read operation may cross row boundaries as shown in Figure 6.

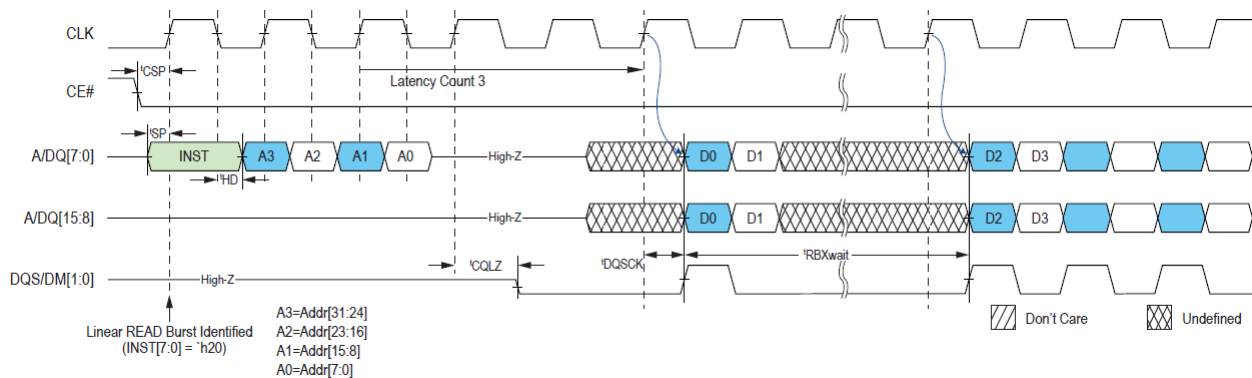

Figure 6: Linear Burst Read with RBX (Starting address '7FE in X8 mode and '3FE in X16 mode)

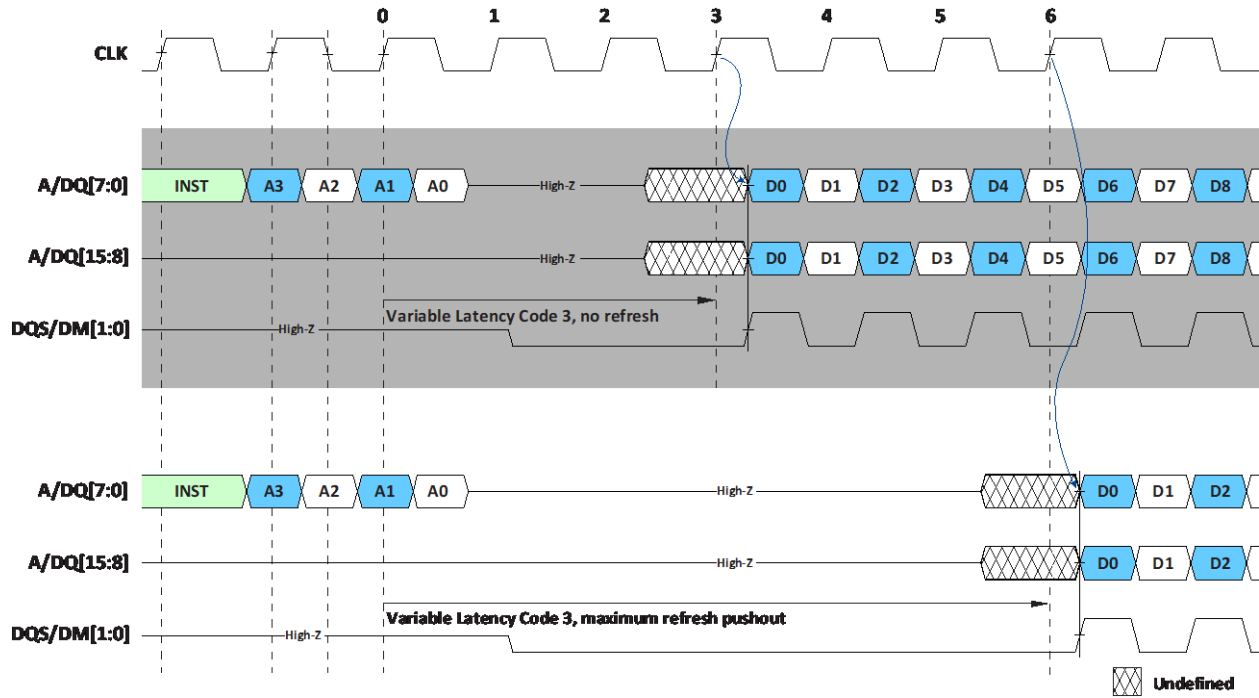
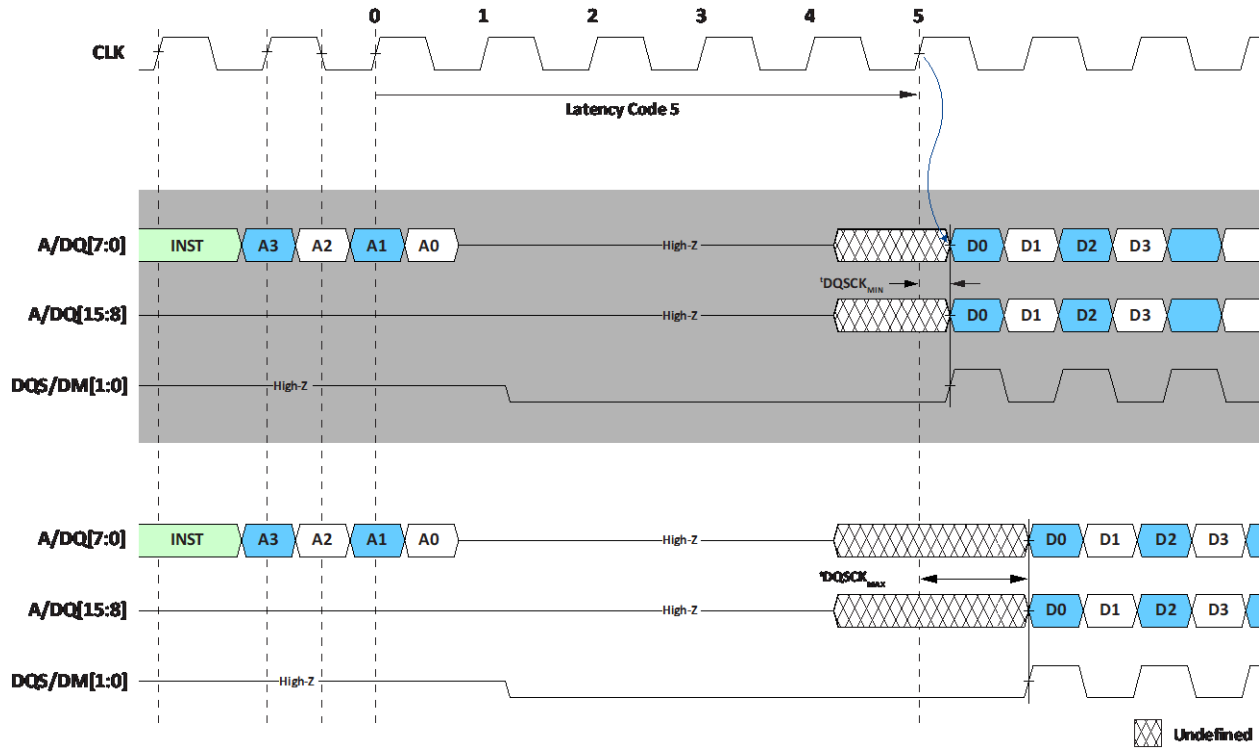

Figure 7: Variable Read Latency Refresh Pushout

 Figure 8: Read Latency & t_{DQSK}

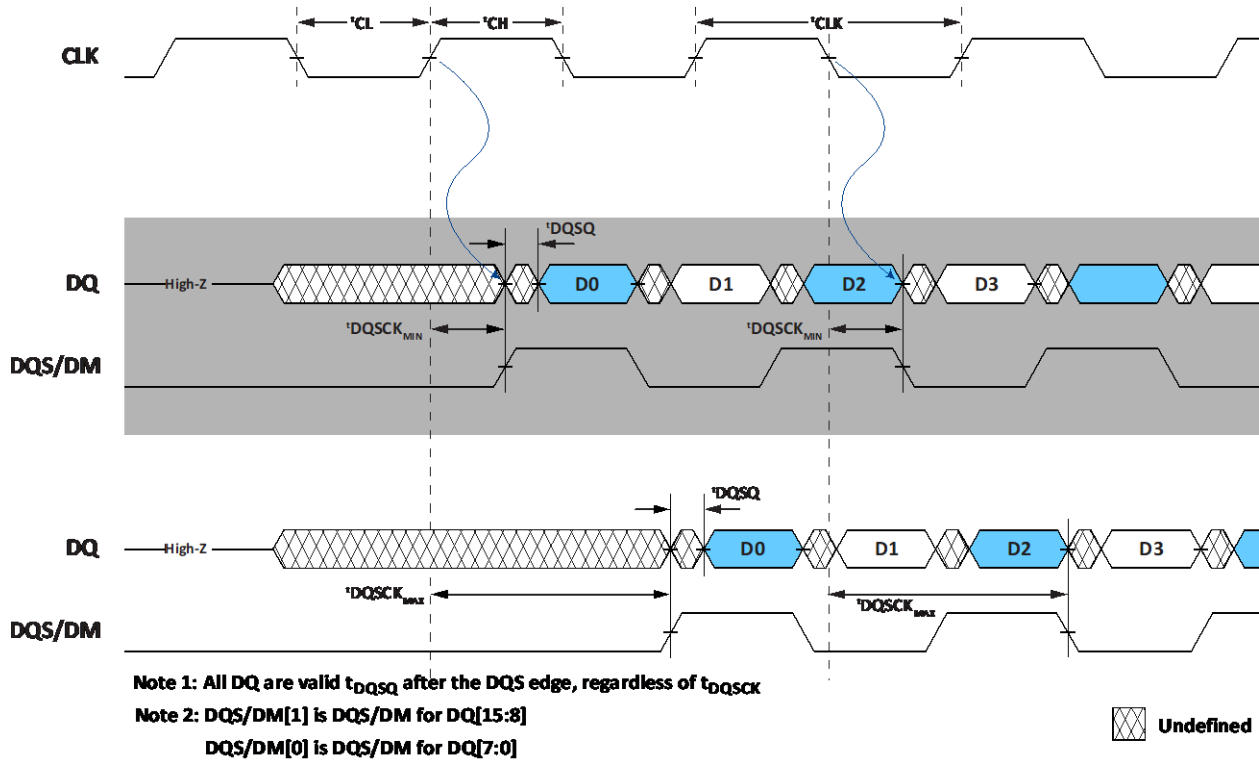

Figure 9: Read DQS/DM & DQ timing

7.6 Write Operation

A minimum of 2 bytes (in X8 mode) / 2words (in X16 mode) of data must be input in a write operation. In the case of consecutive short burst writes, t_{RC} must be met by issuing additional CE# high time between operations. Single-byte write operations can be done by masking through DQS/DM pin as shown in Figure 10.

In X16 mode DQ[15:8] are ignored during INST/ADDR cycles. Instead, DQ[15:8] are only used after write latency to receive the data, similar to DQ[7:0]. During write data cycles the DQ[15:8] and DQ[7:0] can be independently masked via DM[1] and DM[0].

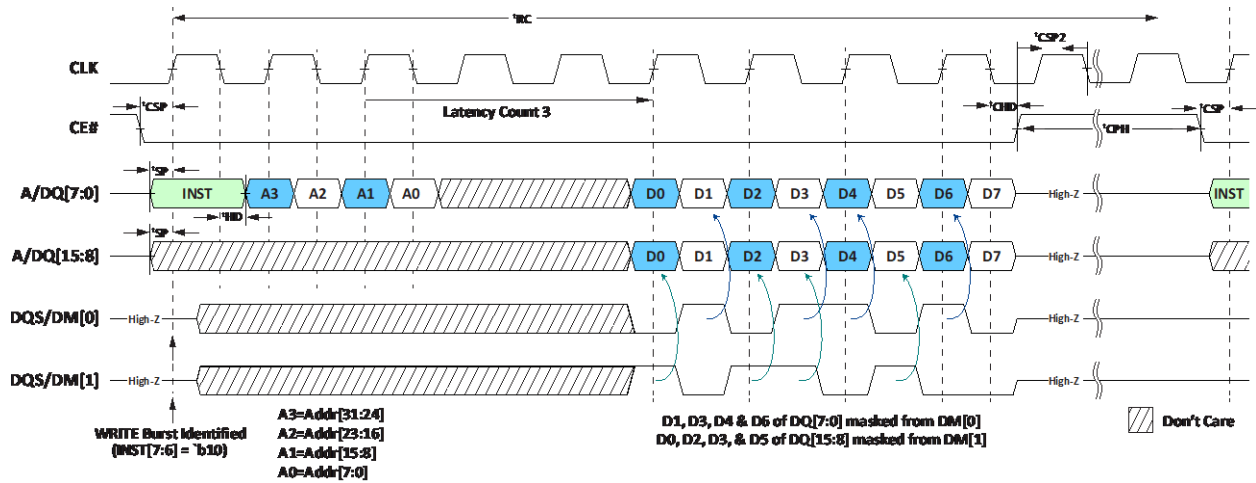

Figure 11: Synchronous Write followed by any Operation

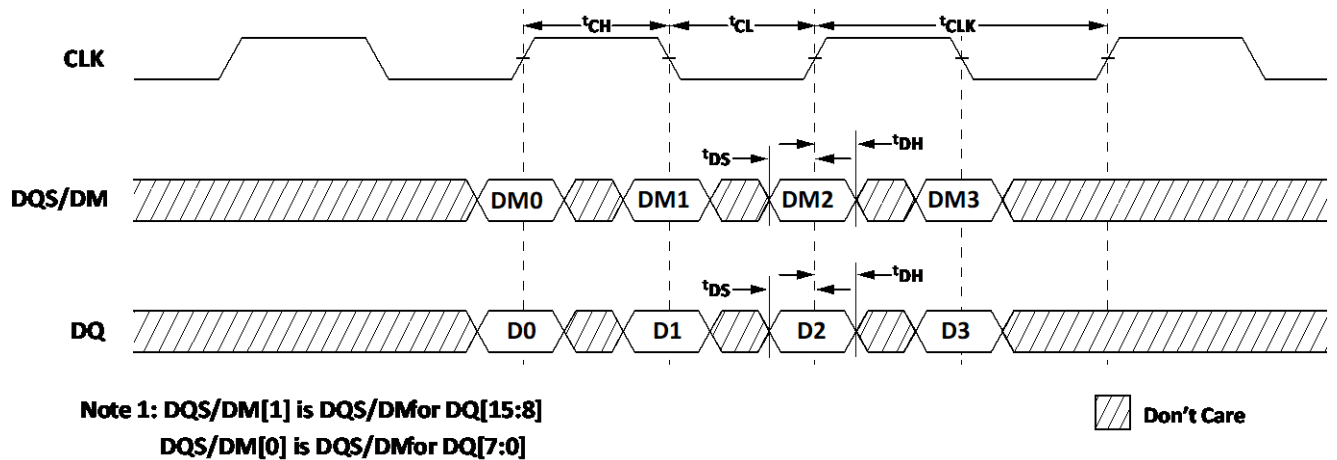

Figure 12: Write DQS/DM & DQ Timing

7.7 Control Registers

Register Read is shown below. Mode Address in command determines which Mode Register is read from as Data0 (see chart in the Figure below). All Mode Registers are 8-bit wide, Mode register write and read uses only A/DQ[7:0] even in X16 mode.

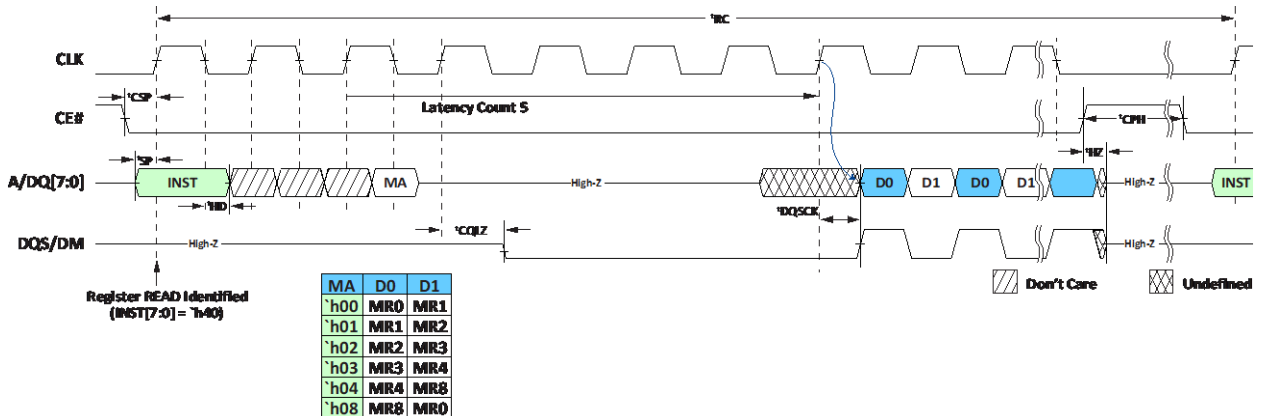

Figure 13: Register Read

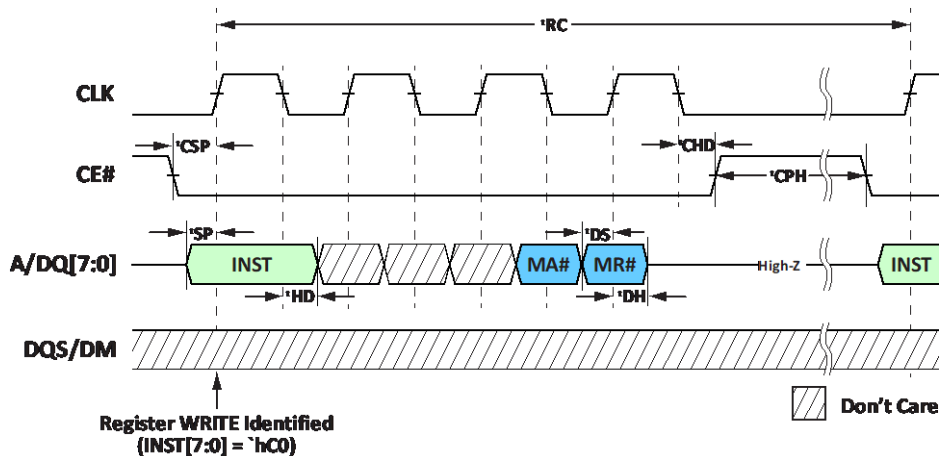

Figure 14: Register Write

Register Writes are always latency 1. Write Latency Code, MR4[7:5] does not apply to Register writes. Register Reads follow the same read latency settings, defined in MR0[4:2] (see Table 6).

Registers 0, 4 & 8 are read and writable. Registers 1, 2 and 3 are read-only. Register 6 is write-only.

Register mapping is shown in Table 3. All MR0 or MR8 writes must have MR0[6] and MR8[7] written to `0(s).

Table 3: Mode Register Table

MR No.	MA[7:0]	Access	OP7	OP6	OP5	OP4	OP3	OP2	OP1	OP0
0	`h00	R/W	TSO	0	LT	Read Latency Code			Drive Str.	
1	`h01	R	ULP	rsvd.		Vendor ID				
2	`h02	R	KGD		Dev ID		Density			
3	`h03	R	RBXen	0	SRF		rsvd.			
4	`h04	R/W	Write Latency Code			RF rate		PASR		
6	`h06	W	Halfsleep™				rsvd.			
8	`h08	R/W	'0'	x8/x16	rsvd		RBX	BT	BL	

Table 4: Read Latency Type MR0[5]

Latency Type	
MR0[5]	LT
0	Variable (default)
1	Fixed

Table 5: Read Latency Codes MR0[5:2]

MR0[4:2]	VL Codes (MR0[5]=0)		FL Codes (MR0[5]=1)	Max Input CLK Freq (MHz)		Notes
	Latency (LC)	Max push out (LCx2)	Latency (LCx2)	Standard	Extended	
000	3	6	6	66	66	
001	4	8	8	109	109	
010	5 (default)	10	10	133	133	
011	6	12	12	166	166	
100	7	14	14	200	200	
101	9	16	16	225	225	1
110	10	18	18	250	250	1

Note 1: The RBX function cannot be used when MR0[4:2] is set to 101, 110 or 111

Table 6: Operation Latency Code Table

Type	Operation	VL (default)		FL
		No Refresh	Refresh	
Memory	Read	LC	Max push out	FLC
	Write	WLC		WLC
Register	Read	≤200MHz LC >200MHz LC-1		≤200MHz LC >200MHz LC-1
	Write	1		1

*Note: see Table 14 for WLC settings.

Table 7: Drive Strength Codes MR0[1:0]

Codes	Drive Strength
'00	Full (25Ω default)
'01	Half (50Ω)
'10	1/4 (100Ω)
'11	1/8 (200Ω)

Table 8: Ultra Low Power Device mapping MR1[7]

ULP	
'0	Non-ULP (no Halfsleep™)
'1	ULP (Halfsleep™ supported)

Table 9: Vendor ID mapping MR1[4:0]

Vendor ID
01101: APM

Table 10: Good-Die Bit MR2[7:5]*

Codes	Good Die ID
'110	PASS
others	FAIL

*Note: Default is FAIL die, and only mark PASS after all tests passed.

Table 11: Device ID MR2[4:3]

Codes	Device ID
'00	Generation 1
'01	Generation 2
'10	Generation 3
'11	Generation 4 (default)

Table 12: Device Density mapping MR2[2:0]

MR2[2:0]	Density
'001	32Mb
'011	64Mb
'101	128Mb (default)
'111	256Mb
'110	512Mb
others	reserved

Table 13: Self Refresh Flag MR3[5:4]

MR3[5:4] indicates current device refresh rate. Refresh rate depends on temperature and refresh frequency configuration, set by MR4[4:3].

MR3[5:4] (read-only)	Self Refresh Flag
01	0.5x Refresh
00	1x Refresh
10	4x Refresh
11	reserved

Table 14: Write Latency MR4[7:5]

Write latency, WLC, is default to 5 after power up. Use MR Write to set write latencies according to write latency table. When operating frequency exceeding Fmax listed in the table will result in write data corruption.

MR4[7:5]	Write Latency Codes (WLC)	Fmax (MHz)
000	3	66
100	4	109
010	5 (default)	133
110	6	166
001	7	200
101	8	225
011	9	250

Table 15: Temperature Sensor Override MR0[7]

<i>Temp Sensor Override</i>	
<i>MR0[7]</i>	<i>TSO</i>
0	On-die thermal sensor controls refresh rate according to MR4[4:3] (default)
1	Force refresh rate set by MR4[4:3]. (host takes on role of on-die built-in thermal sensor)

Table 16: Refresh Frequency setting MR4[4:3]

<i>MR4[4:3]</i>	<i>Refresh Frequency</i>
x0	Always 4x Refresh (default)
01	Enables 1x Refresh when temperature allows (temperature<= 70°C)
11	Enable 0.5x Refresh when temperature allows (temperature<= 50°C)

Note: x= don't care

Table 17: PASR MR4[2:0]

The PASR bits restrict refresh operation to a portion of the total memory array. This feature allows the device to reduce standby current by refreshing only that part of the memory array required by the host system. The refresh options are full array, one-half array, one-quarter array, one-eighth array, or none of the array. The mapping of these partitions can start at either the beginning or the end of the address map.

Address Space: RA [12:0], CA [10:0] Note: CA [10] is ignored in X16 mode.

128Mb X8				
Codes	Refresh Coverage	Address Space	Size	Density
'000	Full array (default)	000000h-FFFFFFh	16M x8	128Mb
'001	Bottom 1/2 array	000000h-7FFFFFFh	8M x8	64Mb
'010	Bottom 1/4 array	000000h-3FFFFFFh	4M x8	32Mb
'011	Bottom 1/8 array	000000h-1FFFFFFh	2M x8	16Mb
'100	None	0	0M	0Mb
'101	Top 1/2 array	800000h-FFFFFFh	8M x8	64Mb
'110	Top 1/4 array	C00000h-FFFFFFh	4M x8	32Mb
'111	Top 1/8 array	E00000h-FFFFFFh	2M x8	16Mb

Address Space: RA [12:0], CA [9:0]

128Mb X16				
Codes	Refresh Coverage	Address Space	Size	Density
'000	Full array (default)	000000h-7FFFFFFh	8M X16	128Mb
'001	Bottom 1/2 array	000000h-3FFFFFFh	4M X16	64Mb
'010	Bottom 1/4 array	000000h-1FFFFFFh	2M X16	32Mb
'011	Bottom 1/8 array	000000h-0FFFFFFh	1M X16	16Mb
'100	None	0	0M	0Mb
'101	Top 1/2 array	400000h-7FFFFFFh	4M X16	64Mb
'110	Top 1/4 array	600000h-7FFFFFFh	2M X16	32Mb
'111	Top 1/8 array	700000h-7FFFFFFh	1M X16	16Mb

Table 18: Halfsleep™ MR6[7:0]

MR6[7:0]	ULP Modes
'hF0	Halfsleep™
'hC0	Deep Power Down
others	reserved

Note: see 7.8 Halfsleep™ Mode; 7.9 Deep Power Down Mode for more information.

Table 19: IO X8/X16 Mode MR8[6]

Device powers up in X8 mode, MR8[6]=0. After power up device can be configured to X16 mode by setting MR8[6]=1 via mode register write command. Host can switch in and out of X16 mode any time after power up.

MR8[6]	X8/X16 Mode
0	X8 (default)
1	X16

Table 20: Burst Type MR8[2], Burst Length MR8[1:0]

By default the device powers up in 32 Byte Hybrid Wrap. In non-Hybrid burst (MR8[2]=0), MR8[1:0] sets the burst address space in which the device will continually wrap within. If Hybrid burst wrap is selected (MR8[2]=1), the device will burst through the initial wrapped burst length once, then continue to burst incrementally up to maximum column address (2K in X8 mode/1K in X16 mode) before wrapping around within the entire column address space. Burst length (MR8[1:0]) can be set to 16,32,64 & 2K in X8 mode (1K in X16 mode) Lengths.

MR8[2]	MR8[1:0]	Burst Length X8/X16 Mode	Example of Sequence of Bytes During Wrap	
			Starting	Burst Address Sequence in X8 mode
'0	'00	16 Byte/Word Wrap	4	[4,5,6,...15,0,1,2,...]
'0	'01	32 Byte/Word Wrap	4	[4,5,6,...31,0,1,2,...]
'0	'10	64 Byte/Word Wrap	4	[4,5,6,...63,0,1,2,...]
'0	'11	2K Byte/1K Word Wrap	4	[4,5,6,...2047,0,1,2,...]
'1	'00	16 Byte/Word Hybrid Wrap	2	[2,3,4,...15,0,1],16,17,18,...2047,0,1,...
'1	'01	32 Byte/Word Hybrid Wrap	2	[2,3,4,...31,0,1],32,33,34,...2047,0,1,...
'1	'10	64 Byte/Word Hybrid Wrap	2	[2,3,4,...63,0,1],64,65,66,...2047,0,1,...
'1	'11	2K Byte/1K Word Wrap	2	[2,3,4,...2047,0,1,2,...]

The Linear Burst Commands (INST[5:0]=6'b10_0000) forces the current array read or write command to do 2K Byte Wrap(X8)/1K Word(X16) (equivalent to having MR8[1:0] set to 2'b11). For non-RBX Enabled devices the burst command read/writes linearly from the starting address and wraps back to the beginning of the page upon reaching the end of the page. To access a different page, host must issue a new command.

Table 21: Row Boundary Crossing Read Enable MR8[3]

This register setting applies to Linear Burst reads only on RBX enabled devices (MR3[7]=1). Default write and read burst behavior is limited within page (row) address space. In X8 mode column address range is 2K (CA='h000 -> 'h7FF) and it is 1K (CA='h000 -> 'h3FF) in X16 mode. Setting this bit high will allow Linear Burst Read command to cross over into the next Row (RA+1).

MR8[3]	RBX Read
0	Reads stay within page (row) boundary
1	Allow reads cross page (row) boundary

7.8 Halfsleep™ Mode

Halfsleep™ Mode puts the device in an ultra-low power state, while the stored data is retained. Halfsleep™ Mode Entry is entered by writing 8'hF0 into MR6. CE# going high initiates the Halfsleep™ mode and must be maintained for the minimum duration of Halfsleep™ time, tHS. The Halfsleep™ Entry command sequence is shown below.

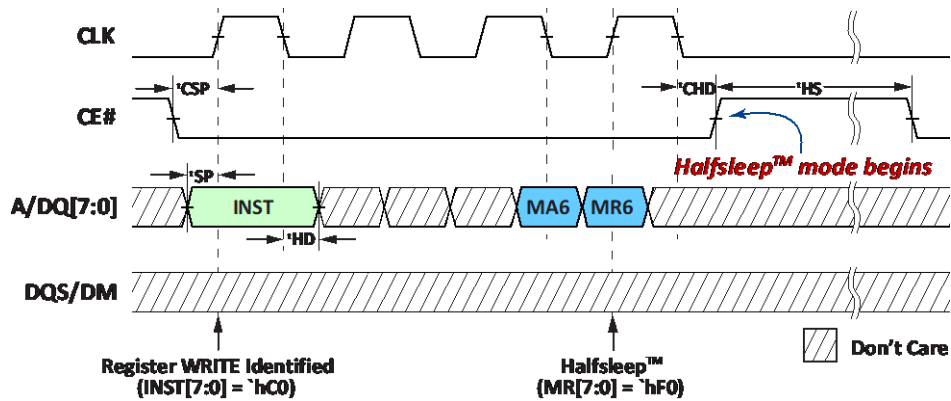

Figure 15: Halfsleep™ Entry Write (latency same as Register Writes, WL1)

Halfsleep™ Exit is initiated by a low pulsed CE#. Afterwards, CE# can be held high with or without clock toggling until the first operation begins (observing minimum Halfsleep™ Exit time, tXHS).

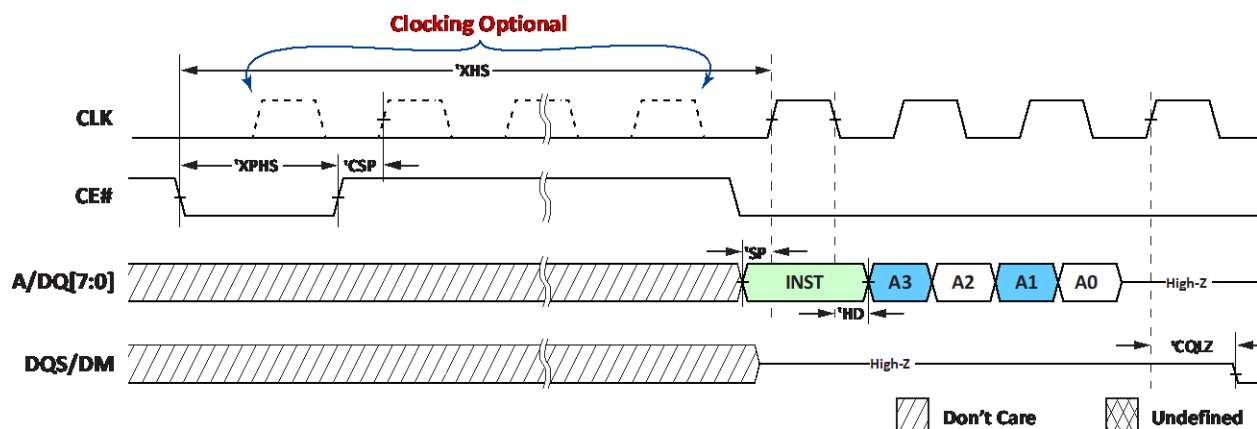

Figure 16: Halfsleep™ Exit (Read Operation shown as example)

7.9 Deep Power Down Mode

Deep Power Down Mode (DPD) puts the device into power down state. DPD Mode Entry is entered by writing 8'hC0 into MR6. CE# going high initiates the DPD Mode and must be maintained for the minimum duration of Deep Power Down time, tDPD. The Deep Power Down Entry command sequence is shown below.

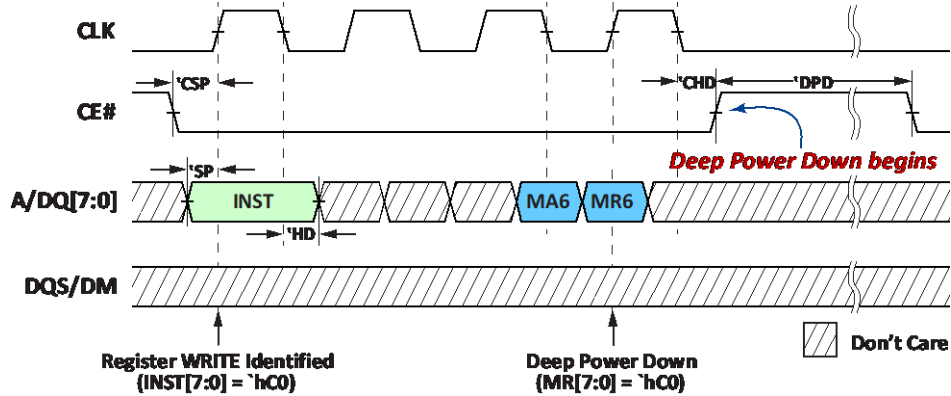

Figure 17: Deep Power Down Entry

Deep Power Down Exit is initiated by a low pulsed CE#. After a CE# DPD exit, CE# must be held high with or without clock toggling until the first operation begins (observing minimum Deep Power Down Exit time, tXDPD).

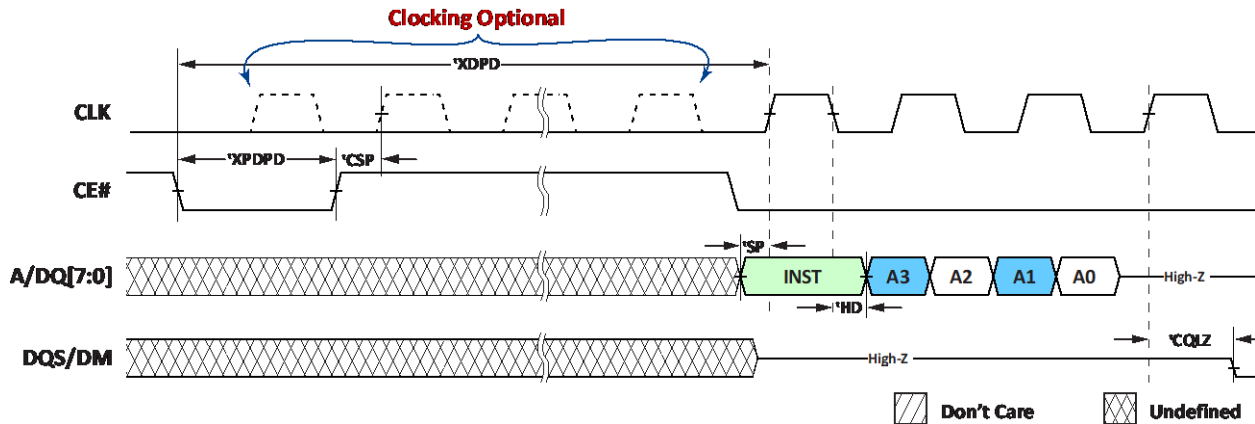

Figure 18: Deep Power Down Exit (Read Operation shown as example)

Register values and memory content are not retained in DPD Mode. After DPD mode register values will reset to defaults. tDPDp is minimum period between two DPD Modes (measured from DPD exit to the next DPD entry) as well as from the initial power up to the first DPD entry.

8 Electrical Specifications:

8.1 Absolute Maximum Ratings

Table 22: Absolute Maximum Ratings

Parameter	Symbol	Rating	Unit	Notes
Voltage to any ball except V_{DD} , V_{DDQ} relative to V_{SS}	V_T	-0.4 to $V_{DD}/V_{DDQ}+0.4$	V	
Voltage on V_{DD} supply relative to V_{SS}	V_{DD}	-0.4 to +2.45	V	
Voltage on V_{DDQ} supply relative to V_{SS}	V_{DDQ}	-0.4 to +2.45	V	
Storage Temperature	T_{STG}	-55 to +150	°C	1

Notes 1: Storage temperature refers to the case surface temperature on the center/top side of the PSRAM.

Caution:

Exposing the device to stress above those listed in Absolute Maximum Ratings could cause permanent damage. The device is not meant to be operated under conditions outside the limits described in the operational section of this specification. Exposure to Absolute Maximum Rating conditions for extended periods may affect device reliability.

8.2 Input Signal Overshoot

During DC conditions, input or I/O signals should remain equal to or between VSS and VDD. During voltage transitions, inputs or I/Os may negative overshoot VSS to -1.0V or positive overshoot to VDD +1.0V, for periods up to 20 ns.

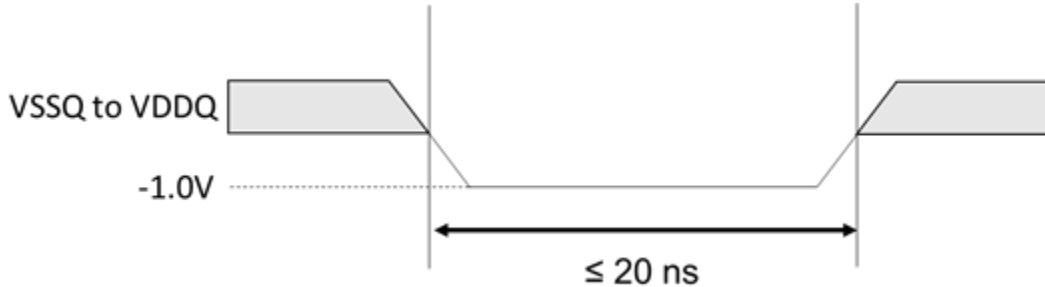

Figure 19 Maximum Negative Overshoot Waveform

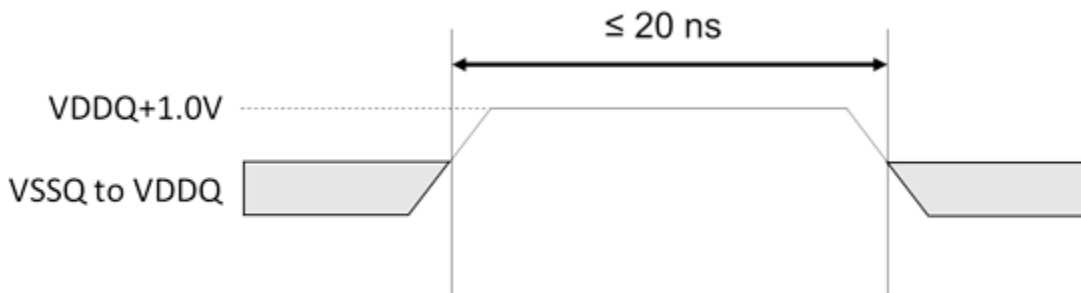

Figure 20 Maximum Positive Overshoot Waveform

8.3 Pin Capacitance

Table 23: Bare Die Pin Capacitance

Parameter	Symbol	Min	Max	Unit	Notes
Input Pin Capacitance	CIN		1	pF	VIN=0V
Output Pin Capacitance	COUT		2	pF	VOUT=0V

Note: spec'd at 25°C.

Table 24: Package Pin Capacitance

Parameter	Symbol	Min	Max	Unit	Notes
Input Pin Capacitance	CIN		2	pF	VIN=0V
Output Pin Capacitance	COUT		3	pF	VOUT=0V

Note: spec'd at 25°C.

Table 25: Load Capacitance

Parameter	Symbol	Min	Max	Unit	Notes
Load Capacitance	C_L		15	pF	

Note: System C_L for the use of package

8.4 Decoupling Capacitor Requirement

System designers need to take care of power integrity considering voltage regulator response and the memory peak currents/usage modes.

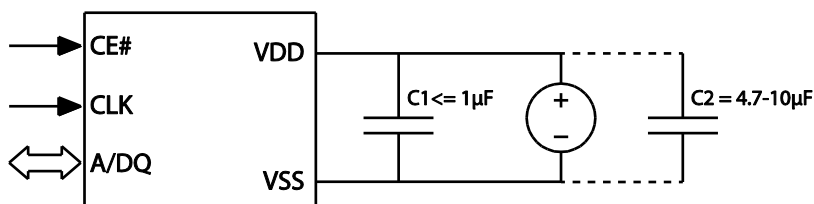

Low ESR cap C1:

It is recommended to place a low ESR decoupling capacitor of $\leq 1\mu\text{F}$ close to the device to absorb transient peaks.

Large cap C2:

Though half-sleep average current is small (less than $100\mu\text{A}$), its peak current from internal periodical burst refresh can reach up to the level of 25mA . The peak current duration can last for few tens of microseconds. During this period if the system regulator cannot supply such large peaks, it is important to place a $4.7\mu\text{F}-10\mu\text{F}$ cap to cover the burst refresh current demand and replenish the cap before the next burst of refresh.

If needed, contact AP Memory for further decoupling solution assistance.

8.5 Operating Conditions

Table 26: Operating Characteristics

Parameter	Min	Max	Unit	Notes
Operating Temperature (extended)	-40	105	°C	
Operating Temperature (standard)	-40	85	°C	

8.6 DC Characteristics

Table 27: DC Characteristics

Symbol	Parameter	Min	Max	Unit	Notes
V _{DD}	Supply Voltage	1.62	1.98	V	
V _{DDQ}	I/O Supply Voltage	1.62	1.98	V	
V _{IH}	Input high voltage	V _{DDQ} -0.4	V _{DDQ} +0.3	V	
V _{IL}	Input low voltage	-0.3	0.4	V	
V _{OH}	Output high voltage (I _{OH} =-0.2mA)	0.8 V _{DDQ}		V	
V _{OL}	Output low voltage (I _{OL} =+0.2mA)		0.2 V _{DDQ}	V	
I _{LI}	Input Pin leakage current		1	μA	
I _{LO}	Output Pin leakage current		1	μA	
ICC	Read/Write @13MHz (X8/X16)		5/6	mA	1
	Read/Write @133MHz (X8/X16)		19/23	mA	1
	Read/Write @166MHz (X8/X16)		22/28	mA	1
	Read/Write @200MHz (X8/X16)		26/33	mA	1
	Read/Write @225MHz (X8/X16)		29/37	mA	1
	Read/Write @250MHz (X8/X16)		32/41	mA	1
ISB _{EXT}	Standby current (105C)		590	μA	2
ISB _{STD}	Standby current (85C)		420	μA	2
ISB _{STDDPD}	Standby current (Deep Power Down -40°C to 85°C)		16	μA	3

Note 1: Current is only characterized.

Note 2: Without CLK toggling. ISB will be higher if CLK is toggling.

Note 3: Typical mean ISB_{STDDPD} 7μA at 25°C.

Note 4: For typical current please refer Table28 & Table29.

8.7 ISB Partial Array Refresh Current

Table 28: Typical-mean PASR Current @ 25°C

Standby Current @ 25°C			
PASR	ISB –typical mean	Unit	Notes
Full	64	μA	1, 2
1/2	58.5	μA	1, 2
1/4	56	μA	1, 2
1/8	55.5	μA	1, 2
Halfsleep™ Current @ 25°C			
PASR	I Halfsleep™-typical mean	Unit	Notes
Full	19.5	μA	1,2,3
1/2	14.5	μA	1,2,3
1/4	12	μA	1,2,3
1/8	11	μA	1,2,3

Table 29: Typical-mean PASR Current @ 105°C/85°C

Standby Current @ 105°C			
PASR	ISB –typical mean	Unit	Notes
Full	310	μA	2
1/2	230	μA	2
1/4	190	μA	2
1/8	170	μA	2
Halfsleep™ Current @ 85°C			
PASR	I Halfsleep™-typical mean	Unit	Notes
Full	230	μA	2, 3
1/2	160	μA	2, 3
1/4	125	μA	2, 3
1/8	108	μA	2, 3

Note1: Current at 25°C is only attainable by enabling 0.5x Refresh Frequency (see Table 17)

Note2: PASR Current is only characterized without CLK toggling.

Note3: Spec'd Halfsleep™ current is only guaranteed after 150ms into Halfsleep™ mode.

8.8 AC Characteristics

Table 30: READ/WRITE Timing

		KGD/BGA 1.8V Only											
		133MHz		166MHz		200MHz		225MHz		250MHz			
Symbol	Parameter	Min	Max	Min	Max	Min	Max	Min	Max	Min	Max	Unit	Notes
tCLK	CLK period	7.5		6		5			4.4		4	ns	
tCH/tCL	Clock	0.45	0.55	0.45	0.55	0.45	0.55	0.45	0.55	0.45	0.55	tCLK	
tKHKL	CLK rise or		1.2		1		0.8		0.7		0.6	ns	
tCPH	CE# HIGH between subsequent	15		18		24			26		28	ns	
tCEM	CE# low pulse width (excluding Halfsleep™)		8		8		8		8		8	μs	Standard temp
			3		3		3		3		3	μs	Extended temp
tCEM	CE# low pulse width	3		3		3		3		3		tCLK	Minimum 3 clocks
tCSP	CE# setup time to CLK	2		2		2		2		1.6		ns	
tCSP2	CE# rising edge to	1.5		1.5		1.5		1.5		1.5		ns	
tCHD	CE# hold time from	2		2		2		2		1.6		ns	
tSP	Setup time to active	0.8		0.6		0.5		0.5		0.5		ns	
tHD	Hold time from active	0.8		0.6		0.5		0.5		0.5		ns	Max 0.75*tCLK
tHZ	Chip disable to		6		6		6		6		6	ns	
tRBXwait	Row Boundary	VL*tCK	(VL+2)*tCK	VL*tCK	(VL+2)*tCK	VL*tCK	(VL+2)*tCK	NA	NA	NA	NA	ns	
tRC	Write Cycle	60		60		60		60		60		ns	
tRC	Read Cycle	60		60		60		60		60		ns	
tHS	Minimum Halfsleep™	150		150		150		150		150		μs	
tXHS	Halfsleep™ Exit CE#	150		150		150		150		150		μs	
tXPHS	Halfsleep™	60		60		60		60		60		ns	
	Exit CE# low pulse width		tCEM		tCEM		tCEM		tCEM		tCEM	μs	Standard temp
													μs

		KGD/BGA 1.8V Only											
		133MHz		166MHz		200MHz		225MHz		250MHz			
Symbol	Parameter	Min	Max	Min	Max	Min	Max	Min	Max	Min	Max	Unit	Notes
tDPD	Minimum DPD duration	500		500		500		500		500		μs	
tDPDp	Minimum period between DPD	500		500		500		500		500		μs	
tXDPD	DPD CE# low to CLK setup time	150		150		150		150		150		μs	
tXPDPD	DPD Exit CE# low pulse width	60		60		60		60		60		ns	
tPU	Device Initialization	150		150		150		150		150		μs	
tRP	RESET# low pulse width	1		1		1		1		1		μs	
tRST	Reset to CMD valid	2		2		2		2		2		μs	

Table 31: DDR timing parameters

		KGD/BGA 1.8V Only											
		133MHz		166MHz		200MHz		225MHz		250MHz			
Symbol	Parameter	Min	Max	Min	Max	Min	Max	Min	Max	Min	Max	Unit	Notes
tCQLZ	Clock rising edge to DQS low	1	6	1	6	1	6	1	6	1	6	ns	
tDQSK	DQS output access time from CLK	2	6.5	2	6.5	2	6.5	2	6.5	2	6.5	ns	
tDQSQ	DQS – DQ skew		0.6		0.5		0.4		0.4		0.4	ns	
tDS	DQ and DM input setup time	0.8		0.6		0.5		0.5		0.5		ns	
tDH	DQ and DM input hold time	0.8		0.6		0.5		0.5		0.5		ns	

9 Change Log

Version	Who	Date	Description
0.01		July 12, 2021	Initial Version From E8 XX 0.04a version Removed RBX function Performance: 200MHz → 250MHz
0.02		Sep 28, 2021	Update part number.
0.03	Jacky	Oct 21, 2021	1.tCEM revised data by BD suggest (E8_OPI_64Mb/128Mb) Standard temp: 4 us -> 8 us. Extended temp: 1 us -> 3 us. 2.Revised Max Frequency = 200MHz of APS128XXO-OBx9-BG
0.04	Jacky	Jan 21, 2022	Revised typo from “256M in X16 mode” to “256Mb in X16 mode” Add RBX description and note it RBX only support maximum frequency of 200MHz Revised value of tRBXwait to NA on 225/250Mhz.
0.05	Jacky	Feb 11, 2022	Revised typo from “256M” to “128Mb.
0.06	Kim	Aug 3, 2022	Revised typos
0.07	Kim	Aug 16, 2022	Modified below items: 1. tSP/tHD/tDS/tDH to 0.5ns 2. Add tCSP2 SPEC
0.08	Kim	Jan 17, 2023	Modified RL code and add more code setting for revision. Modified tCHD related wording for better understanding.
0.09	Kim	Mar 23, 2023	Add tCHD on read waveform.
1.0	Kim	Jul 17, 2023	Remove tQH on DQS & DQ timing waveform Adjust the description about interface.
1.1	Kim	Nov 28, 2023	Modify PASR table and Halfsleep typical current Add chapter8.2 Input signal overshoot
1.2	Kim	Apr 11, 2024	Modify Operation latency code table. tRBXwait description modification